

Bose® 201® and 301® Series V Direct/Reflecting® Speakers

Owner's Guide

BOSE®

®

Where to find...

English

Setting Up	8
Before you begin	3
Unpack the carton	3
For your records	3
Select the locations for your 201® or 301® speakers	4
Choose the cord	5
Prepare the cord	5
Make the connections	6
Test the speakers	6
Using and Maintaining Your Speakers	7
Enjoying sound in a variety of ways	7
Cleaning the speakers	7
Reference	8
Troubleshooting	8
Customer service	8
Warranty period	8
Technical information	9
Optional accessories	9

Before you begin

Your 201® or 301® Series V Direct/Reflecting® speakers recreate a natural balance of reflected and direct sound energy for an open, spacious performance. They are designed by Bose® to bring you high-quality listening pleasure.

These speakers are significantly different from conventional speakers, so be sure to read this owner's guide. It will help you set up and use your speakers properly, for the greatest enjoyment.

Unpack the carton

Carefully unpack the carton and save all packing materials for possible future use. Check the carton contents (Figure 1).

If either speaker appears damaged, do not use them. Instead, repack both speakers in the original carton and notify your authorized Bose dealer immediately.

Note: Now is a good time to record the speaker serial numbers below and on your warranty card.

CAUTION: To avoid danger of suffocation, keep the plastic bags that wrap these speakers out of the reach of children.

Figure 1

What comes in the carton

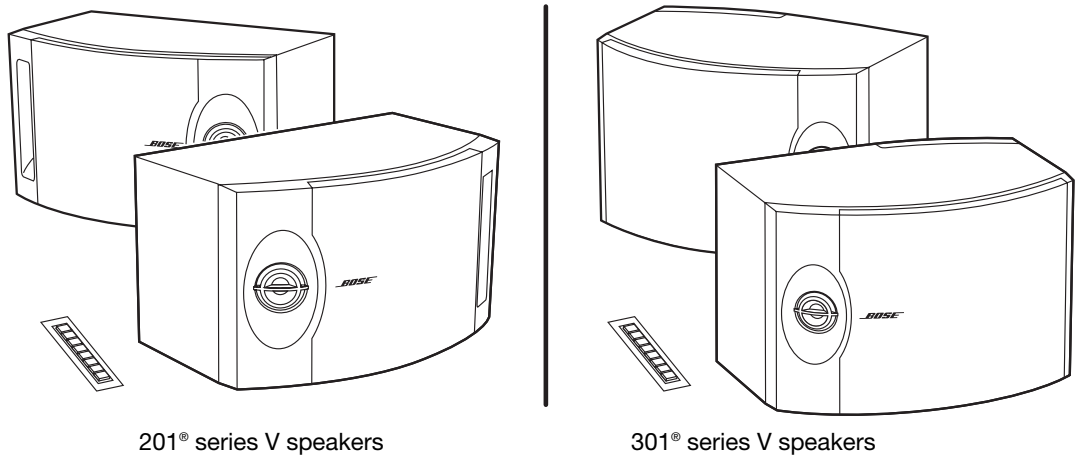

201® series V speakers

301® series V speakers

For your records

Serial numbers are located on the back of each speaker.

Serial number: _____ and _____

Dealer name: _____

Dealer phone: _____ Purchase date _____

We suggest you keep your sales slip and warranty card together with this owner's guide.



Choose the cord

It is important to use the proper gauge (thickness) of speaker cord.

Wire recommendations

Based on a maximum frequency response deviation of ± 0.5 dB

Gauge	Length
18 (0.82 mm ²)	20 ft (6 m)
16 (1.3 mm ²)	30 ft (9 m)
14 (2.1 mm ²)	50 ft (15 m)

♪ **Note:** Before running the speaker cord through a wall or under a floor, check your local building code requirements and safety regulations. If necessary, contact an electrical installer for this information.

Prepare the cord

Speaker cord consists of two insulated wires. The insulation around one wire is marked (striped, collared, or ribbed).

At the ends of each cord, strip approximately $\frac{1}{2}$ inch (12 mm) of insulation from both wires. Twist the bare end of each wire so loose strands will not touch across terminals. Be sure to connect each wire to the proper terminal (positive to positive and negative to negative).

♪ **Note:** It is sometimes difficult to distinguish wire markings. Inspect both wires carefully.

Make the connections

Just press the terminal tab on the back of each speaker to insert the appropriate wire (Figure 3).

CAUTION: Before making any connections, turn off your receiver and unplug it from the AC power (mains) outlet. Not doing so may result in damage to your system.

CAUTION: Never use broken or frayed wiring, which can result in electrical shock or damage.

1. Connect one speaker cord to your right speaker.
 - Attach each marked wire (+) to the appropriate (+) terminal.
 - Attach each plain wire (-) to the appropriate (-) terminal.
2. Connect the other end of the same cord to the RIGHT SPEAKER OUTPUT of your receiver.
 - Attach each marked wire (+) to the appropriate (+) terminal.
 - Attach each plain wire (-) to the appropriate (-) terminal.
3. Connect the second cord to the left speaker and LEFT SPEAKER OUTPUT. Follow the steps in 1 and 2 above.

Figure 3

How to make terminal connections

Test the speakers

To make sure your speakers operate correctly:

1. Turn on your receiver. Set the receiver to MONO (monophonic), if that is an option on your receiver.
2. Make sure that all special effects (such as surround sound) are turned off.
3. Set the balance control to normal (center position).
4. Play some deep bass passages of music through the speaker.

The sound should seem to come from a point between the two speakers. The bass should be full and natural. If it is not, one of the connections may be reversed, causing the speakers to play out of phase (refer to “Make the connections” above).

To correct the problem, make sure all the wires are connected positive to positive (+ to +) and negative to negative (- to -). Then repeat steps 1 through 4 above to re-test the speakers.

Enjoying sound in a variety of ways

Your 201® or 301® speakers are designed to work with a variety of stereo receivers and amplifiers as either front or rear channel speakers. The open, spacious performance of these speakers makes them an ideal choice for home theater, or for listening to CD's, tapes, or radio broadcasts (Figure 4).

Figure 4

301 and 201 series V
speaker sound path

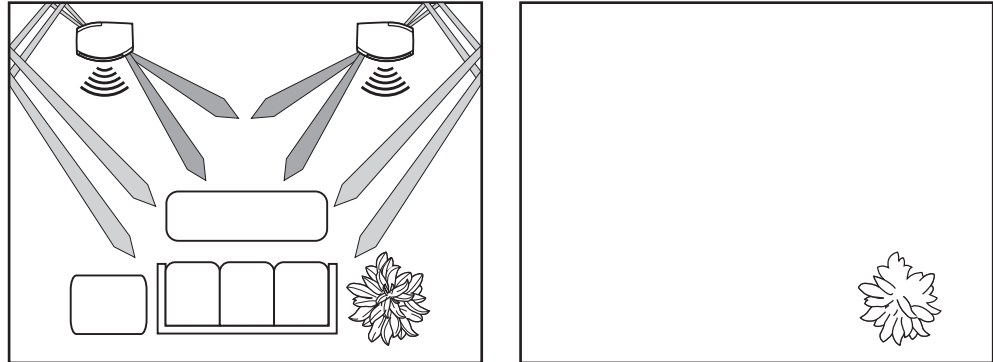

Cleaning the speakers

Clean the surface of your speakers with a soft damp cloth. Do not use any sprays near the system or allow liquids to spill into any openings. Also, do not use any solvents, chemicals, or cleaning solutions containing alcohol, ammonia, or abrasives.

The speaker grille panels require no special care. You may vacuum them carefully to remove dust.

Troubleshooting

Problem	What to do
No sound	<ul style="list-style-type: none"> • Make sure the receiver is plugged in and turned on. • Check to be sure the AC power (mains) outlet is working. • Disconnect any headphones plugged into the headphone jack. • Make sure the receiver is not set to MUTE. • Refer to the owner's guide that came with your receiver. • Check connections to both the speakers and the receiver. Refer to "Make the connections" on page 6. Correct any connection errors.
No sound from one speaker	<ul style="list-style-type: none"> • Disconnect the working speaker from the receiver. • Switch the cord of the "faulty" speaker from its original receiver jacks to the other set of jacks (the working speaker was originally attached to those jacks). <ul style="list-style-type: none"> – If the speaker now works, the problem is in your receiver. – If the speaker does not work, continue below. • Remove the cord from the working speaker and connect it to the "faulty" speaker and either set of receiver jacks. <ul style="list-style-type: none"> – If the speaker now works, the problem was in the original speaker cord. – If the speaker does not work, the problem is in the speaker.
One speaker sounds distorted	<ul style="list-style-type: none"> • Follow the same procedure for the problem of no sound from one speaker, as outlined above.
Not enough bass or treble	<ul style="list-style-type: none"> • Adjust the bass and treble controls on the receiver. • Check the connections to make sure they are correctly in phase (+ to + and – to –). Refer to "Make the connections" on page 6. • Move the speakers closer to or farther from the side walls or other sound-reflecting hard surfaces. • Do not place the speakers exactly halfway between the floor and ceiling or any other sound-reflecting hard surface.

Customer service

If the troubleshooting guidelines above do not solve your problem, contact your authorized Bose® dealer to arrange for service. To obtain information or service directly from Bose, see the list of telephone numbers included with your speakers. Bose Corporation will make every effort to correct any problem within the terms of your warranty.

Warranty period

Bose 201® and 301® series V Direct/Reflecting® speakers are covered by a limited transferable warranty. Details of the coverage are provided on the warranty card that came with your speakers. Please fill out the information section on your card, detach, and mail to Bose.

Technical information

Features

Direct/Reflecting® speaker technology
 Stereo Targeting® tweeters
 Tuned port enclosure
 Syncom® computer quality control

Driver complement

201®: One 6.5-inch (16.5 cm) woofer. One 2-inch (5 cm) tweeter.
 301®: One 8-inch (20 cm) woofer. Two 2-inch (5 cm) high-sensitivity tweeters.

Compatibility/impedance

201: Compatible with amplifiers and receivers rated from 10 to 120 watts per channel.
 Rated 4 - 8 ohms
 301: Compatible with amplifiers and receivers rated from 10 to 150 watts per channel.
 Rated 4 - 8 ohms

Enclosure

Polymer and vinyl veneer over wood construction with black or light cherry finish.

Size/Weight

201: 8"H x 13 ³/₄"W x 8 ⁵/₈"D (20 cm x 35 cm x 22 cm).
 Each speaker, unpacked: 11 lb (5 kg).
 Speaker pair in shipping carton: 25.2 lb (11.4 kg).

301: 9 ³/₄"H x 14 ¹/₄"W x 9 ³/₄"D (25 cm x 36 cm x 25 cm).
 Each speaker, unpacked: 12.5 lb (5.7 kg).
 Speaker pair in shipping carton: 28.7 lb (13 kg).

Optional accessories

Bose® FS-01 speaker stands and WB-3 wall mounting brackets are designed for use with 201 and 301 Series V Direct/Reflecting speakers. For information, or to order accessories, contact your authorized Bose dealer. To contact Bose directly, see the list of telephone numbers included with your speakers.

Figure 5

A. Bose FS-01 speaker stand

B. WB-3 wall mounting brackets

